



PURPOSE

To establish guidelines when permits will be issued for legal size loads including vehicles exceeding axle weight limitations allowed on the state system, but not exceeding gross axle weight limitations allowed on the interstate system.

This permit is valid for non-divisible loads that can bridge their weight. Loads exceeding allowed bridge weights will be required to purchase a single trip permit.

POLICY STATEMENT

As authorized by NDCC 39-12-05.3, subsection 8, the North Dakota Highway Patrol (NDHP), in cooperation with North Dakota Department of Transportation (NDDOT), may exempt certain vehicles from axle grouping gross weight limitations. The NDHP and NDDOT may designate routes to be traveled by those vehicles exempted due to bridge or other structure restrictions. The NDHP shall issue an annual bridge length permit for all vehicles to be exempted. The NDHP has the authority to inspect the vehicles and may revoke the permits at any time if the vehicles have been altered.

PROCEDURE

A. Vehicle Requirements

1. A single unit truck shall be allowed the same gross axle weights on the state system as allowed on the interstate system (see illustrations below).
2. Vehicles must have sufficient number of axles and bridge lengths for gross weights desired as shown on the Weight Limitations Chart.
 - a. No axle in a group of axles shall exceed 19,000 pounds.
 - b. No tire shall exceed 550 pounds per inch width of tire.
3. On a vehicle equipped with more than four axles, additional axles shall be steerable, castering, or pivoting axles.
4. Vehicles manufactured after July 31, 2005, and with more than one variable load suspension or lift axle shall have the lock or pressure regulator valve or both located outside the cab and inaccessible from the driver's compartment.
5. Tires and axle weights must be legal.
6. The maximum gross vehicle weight may not exceed 80,000 pounds.
7. Vehicles must be legally registered for the gross weight of the vehicle and load.

B. Travel Restrictions

1. Permit must be in possession prior to starting any movement.
2. During spring load restrictions the weight on a group of three or more axles will be reduced to 48,000 pounds on state highways restricted by legal weights, 42,000 pounds on 8-ton highways, 36,000 pounds on 7-ton highways, and 30,000 pounds on 6-ton and 5-ton highways.
3. The bridge length permit cannot be used in conjunction with the 10-percent weight exemption permit.

C. Application Procedure

1. Bridge length permits may be purchased online at www.nd.gov/ndhp, click on E-permits.
 - a. Permits purchased online are automatically issued unless submitted for review by the applicant.
 - b. Information required to obtain a single trip permit:
 - 1) Owner's name, address, and telephone number
 - 2) Vehicle description: year, make, serial number, license number, registered gross vehicle weight
 - 3) Axle spacings, number of tires, and tire width
 - 4) Approved weight
2. Single trip permits may also be obtained from the NDHP permit office, motor carrier inspectors, or troopers.

Bridge Length Permit Policy

Ref: Policy 9-2.1 (8/2023)

Page 2

- a. Applications to the permit office may be made in person, by telephone, by e-mail, or through a permit service company.
- b. Applications may also be made with a trooper or motor carrier inspector, in person or by telephone.
3. The bridge length permit will be issued to vehicles that qualify for the axle weight exemption. The annual fee is \$150, 30-day fee is \$50, and the fee for a single trip permit is \$30.
 - a. The annual permit is valid for a twelve-month period from the date of issuance, or it expires December 31st.
 - b. The 30-day permit is valid for 30 days.
 - c. A single trip permit will be valid for a one-way trip not to exceed five days.
 - d. A \$8 service/routing fee is added to each single trip permit.
4. A legible electronic or paper copy of the permit must be in possession prior to entering North Dakota or starting movement.
 - a. The applicant/driver is responsible for complying with the travel restrictions and safety requirements listed on the permit.
5. Any altering of equipment that has been approved for exemption will void the bridge length permit.
6. Applications for a bridge length permit can be obtained from the North Dakota Highway Patrol, Permit Office, 600 E Boulevard Avenue Dept. 504, Bismarck, ND 58505-0240. The telephone number is 701-328-2621.
7. Illustrations.
 - a. The following illustrations are examples of trucks that can be approved for a bridge length permit.

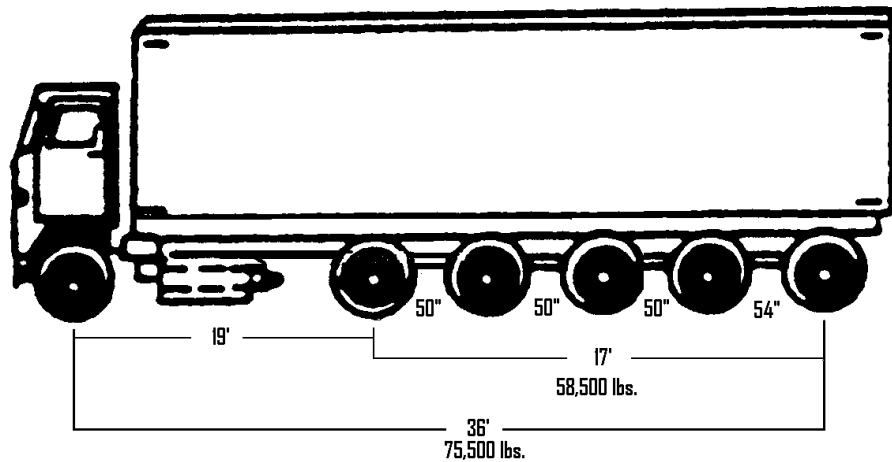

Steering Axle Weight

17.5" = 19,250 lbs

5 Axle Grouping Weights

58,500 lbs on state system with bridge length permit

48,000 lbs without permit

58,500 lbs on interstate system (I-29 & I-94) – no permit required

Gross Vehicle Weight of "Example" Vehicle

75,500 lbs on state system with bridge length permit

67,250 lbs on state system without approval

75,500 lbs on interstate system (I-29 & I-94) – no permit required

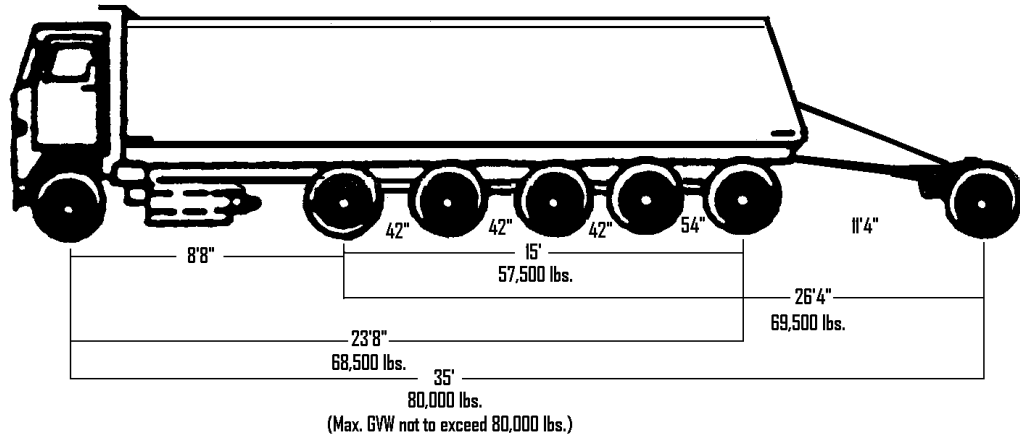

No tire shall exceed 550 pounds per inch width of tire.

Steering Axle Weight

425 mm = 16.7" tire = 18,370 lbs

5 Axle Grouping Weights

57,500 lbs on state system with bridge length permit

48,000 lbs on state system without permit

57,500 lbs on interstate system (I-29 and I-94) – no permit required

Single Axle Weight (stinger)

11" tire – 12,100 lbs

Gross Vehicle Weight of "Example" Vehicle

80,000 lbs on state system with bridge length permit

78,470 lbs on state system without permit (5 axle group cannot exceed 48,000 lbs)

80,000 lbs on interstate system (I-29 & I-94) – no permit required