



# APPLICATION FOR EMERGENCY SURFACE DRAIN

NORTH DAKOTA DEPARTMENT OF WATER RESOURCES

REGULATORY DIVISION

SFN 62710 (4/2026)

No.
-----

(DWR USE ONLY)

<p>Submit To - <a href="mailto:dwrregpermits@nd.gov">dwrregpermits@nd.gov</a>          Department of Water Resources          1200 Memorial Highway   Bismarck, ND 58504</p>
--

<p>DEPARTMENT OF          WATER RESOURCES          USE ONLY</p>
---

This application must include a map from an aerial photograph showing the location as section-township-range format. Include a physical footprint of all proposed drain features, identify existing road culverts and any proposed crossing modifications, and indicate flow direction from drain outlet location.

Additional sheets may be attached if necessary.

## SECTION A - CHECKLIST

Include The Following Information (initial each item)	
_____	Completed SFN 62710 Application For Emergency Surface Drain
_____	Certification Submittal Of Application To Both Department Of Water Resources And Water Resource District (N.D.A.C. § 89-02-05.1-06)
_____	List And Contact Information For All Adjacent Landowners Within One Mile From Outlet Discharge Point (N.D.A.C. § 89-02-05.1-05)
_____	Copies Of Any Written Permission Received From Downstream Landowners (N.D.A.C. § 89-02-05.1-05)
_____	Written Permission Allowing Department And Water Resource District To Inspect Emergency Drain (N.D.A.C. § 89-02-05.1-05)

## SECTION B - LOCATION OF EMERGENCY DRAIN

1/4	1/4	Section	Township	Range
Surface Area Of Pond, Slough, Lake, Sheetwater, Or Any Series Thereof To Be Drained (acres)				
Volume To Be Drained (acre-feet)				
Description Of Emergency				
Water Resource District In Which Majority Of Project Watershed Is Located				Date

**SECTION C - DRAINAGE METHOD**

Type Of Drainage Method (mark all that apply)

Gravity (See Subsection 1)

Pumping (See Subsection 2)

**SUBSECTION 1 - GRAVITY**

Gravity Type (please fill appropriate fields below)

Ditch

Pipe

Length Of Drain (feet)

Maximum Cut (D) (feet)

Bottom Width (B) (feet)

Side Slopes (S:1 foot)

Pipe Diameter (feet)

Pipe Slope (feet per foot)

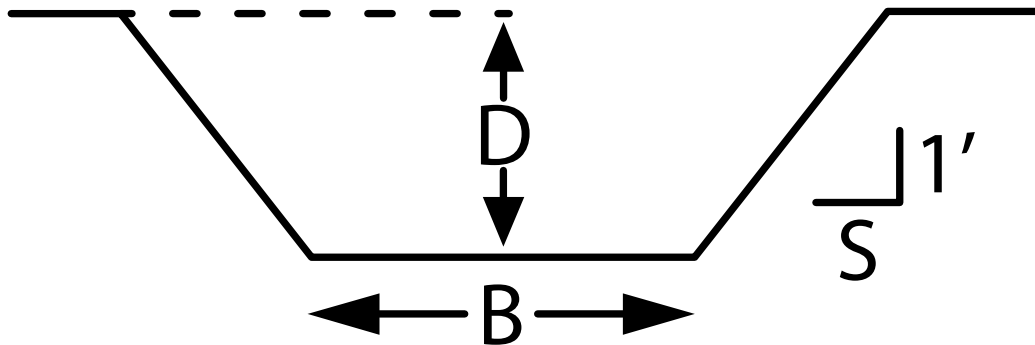

**SUBSECTION 2 - PUMPING**

Pumping Rate (gallons per minute)

Pumping Rate (cubic feet per second)

Pump Style

Movable

Fixed Or Stationary

Pump Type

Submersible

Other \_\_\_\_\_

Anticipated Construction Start Date

Anticipated Construction Completion Date

**APPLICANT'S CERTIFICATION**

I, the undersigned, am applying for permit required under N.D.C.C. § 61-32-03. I understand that I must comply with N.D.C.C. § 61-32-03, N.D.A.C. art. 89-02, relevant Department of Water Resources policies, and any conditions required by the Water Resource District or Department of Water Resources as part of an approved permit for this application. Additionally, I acknowledge that my project is accurately described and depicted in this application and enclosed materials as I intend to construct it. My signature below acknowledges that I have read and agree to these statements.

Affiliation To Proposed Drain			
<input type="checkbox"/> Landowner	<input type="checkbox"/> Renter/Tenant	<input type="checkbox"/> Water Resource District/Agency	
<input type="checkbox"/> Other _____			
Applicant Name (if not an individual, please list organization name)			
Address	City	State	ZIP Code
Telephone Number		Cell Phone Number	
Email Address			
Applicant Signature			Date
Landowner Name (print) (if not the applicant)			
Landowner Signature (if not the applicant)			Date